

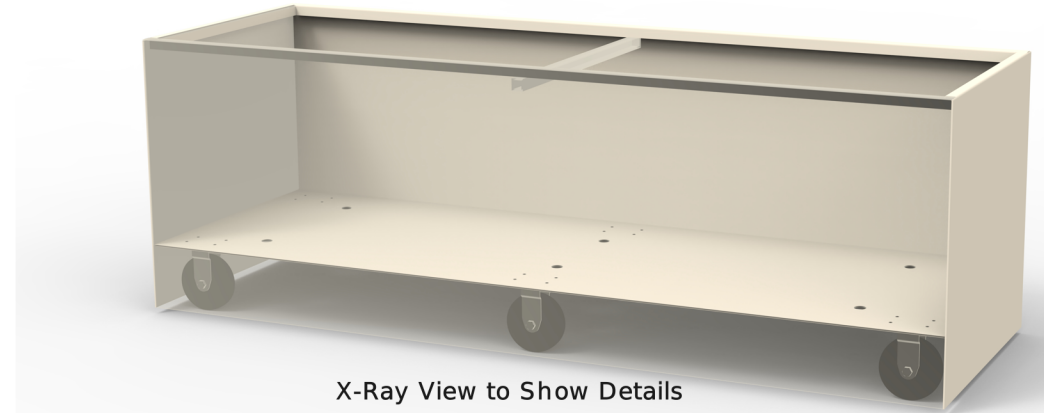

CLASSICS - FLUX

PRODUCT DESCRIPTION: The Flux planter is all about adaptability. Featuring the classic rectangular shape elevated on wheeled castors that make this planter mobile, adding another dimension of flexibility to your design. The perfect addition to both indoor and outdoor environments, built to withstand the complexities of the urban landscape.

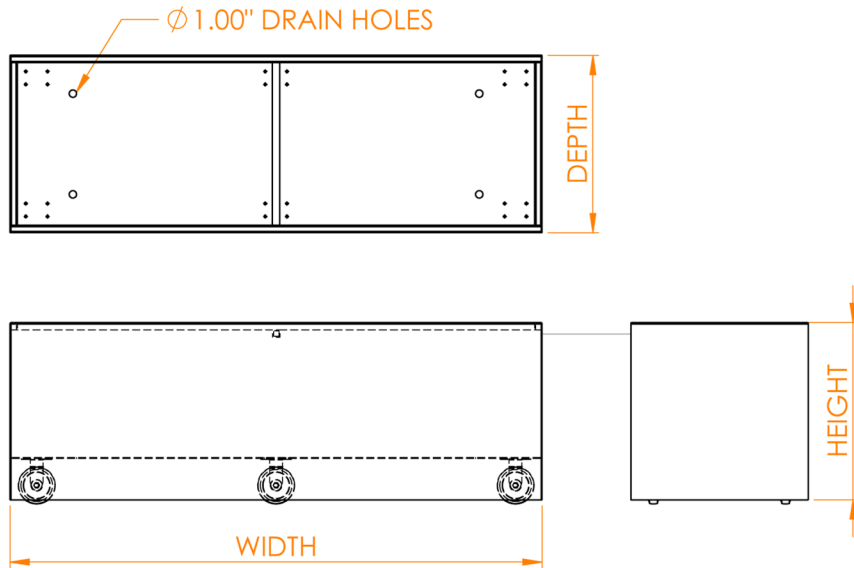

This product can be customized in size, material & finish.

Offered materials include:

1/8" aluminum ASTM B-209, 5052 alloy with a polyester based architectural/marine grade powder coat finish. Offered in our standard finishes or any RAL color, 1/8" standard mill finish stainless steel & brushed finish stainless steel ASTM A240 stainless steel T-304,T-316"L, 1/8" Corten Steel ASTM A588OR with natural patina finish.

Check out a list of our popular custom integrations:

Integrated LED Lighting: Toe-Kick, Front Lighting, Light curtain, Inside under Lip

Integrated Speakers

Irrigation sleeve

Drainage accommodations

Lattice/Trellis

Seating

Your specified accommodations & integrations, you've got an idea? We can help.

Like this product?

Contact us indicating product name, desired size, material, finish, and your choice of custom integrations.

LEGAL:

All Rights Reserved. Information in this document is confidential and is exclusive property of OnSiteFX Incorporated. Delivery of this document or any copy thereof or disclosure of such information to unauthorized persons is forbidden without expressed written permission of OnSiteFX Incorporated.



1014 Grand Blvd #1
Deer Park, NY 11729
646.246.8289
info@OnSiteFX.com
OnSiteFX.com